

A close-up, high-contrast photograph of several large, dark steel pipes. The pipes are arranged in a way that creates a sense of depth and perspective, with some in the foreground and others receding into the background. The lighting is dramatic, highlighting the metallic texture and the circular openings of the pipes.

post+column

**steel** signpost  
systems



# steel signpost systems

## Standards

The company manufactures a full range of sign posts and structures suitable for a wide variety of highway applications. We are fully registered to BS EN ISO 9001 and our fabricators and welding procedures are independently certified to BS EN 287 and BS EN ISO 15614-1. All posts are manufactured to EN12899 and the company is fully registered to National Highway Sector Scheme 6.



## Corrosion Protection

A variety of protective and finishes are available including:

### PLASTIC COATING

- PVC or PPA coatings.
- Our high specification PPA coatings offer a more durable finish with a life of 25 years.
- All coatings can be supplied in a range of colour options.

### GALVANISED

- All our galvanizing is undertaken by specialist companies.
- All are approved to BS EN ISO 1461.

### PAINTED

- A range of paint finishes is available all applied by in house by our skilled operatives.

Finishes available include:

- Vinyl primer/sealers - Single pack  
Life 15 years.  
Available in MIO or Glass Reinforced options.
- Acrylics – Twin Pack  
Life 20 years+ Very durable.  
Available in High Build options.
- Poly Siloxane finishes – Twin Pack  
Extended life expectancy 25 years.  
High solids content.



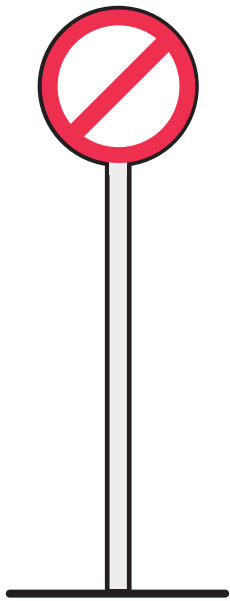

**Straight Post**

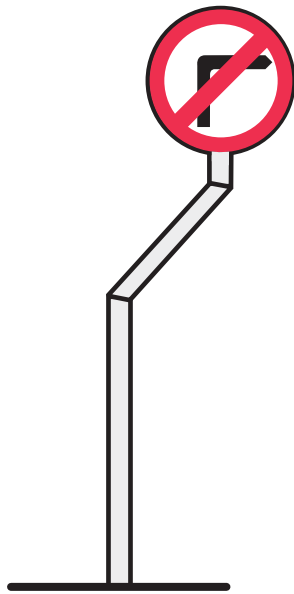

**Cranked Post**

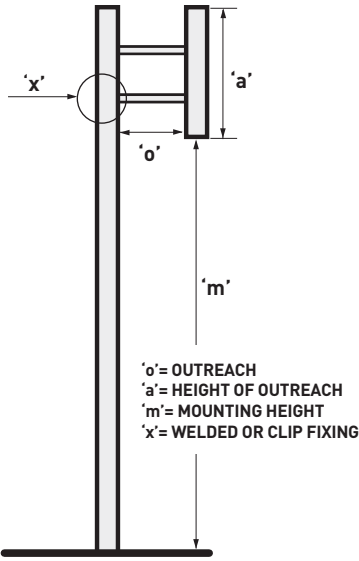

**Off-Set Posts**

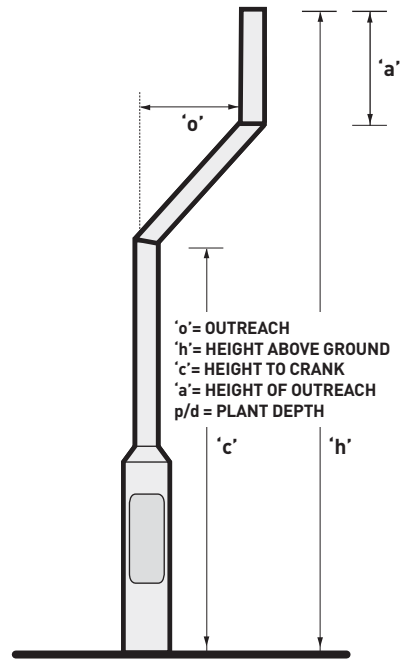

**Cranked Large Base**

'o' = OUTREACH  
'h' = HEIGHT ABOVE GROUND  
'c' = HEIGHT TO CRANK  
'a' = HEIGHT OF OUTREACH  
p/d = PLANT DEPTH

'o' = OUTREACH  
'a' = HEIGHT OF OUTREACH  
'm' = MOUNTING HEIGHT  
'x' = WELDED OR CLIP FIXING

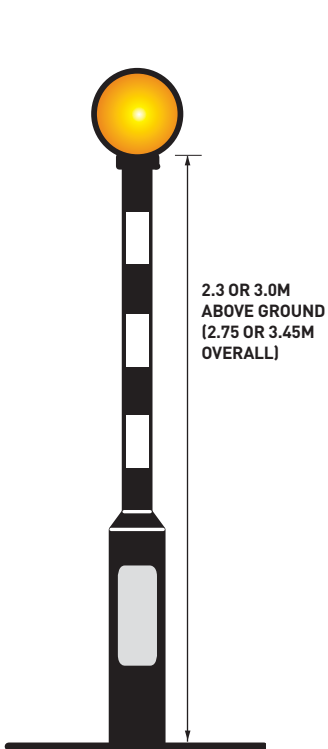

**Belisha Beacon  
2 or 3 Band**

2.3 OR 3.0M  
ABOVE GROUND  
(2.75 OR 3.45M  
OVERALL)

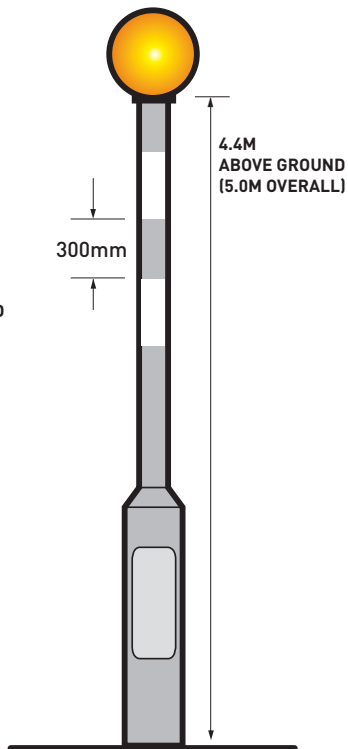

**Refuge Beacon**

4.4M  
ABOVE GROUND  
(5.0M OVERALL)

300mm

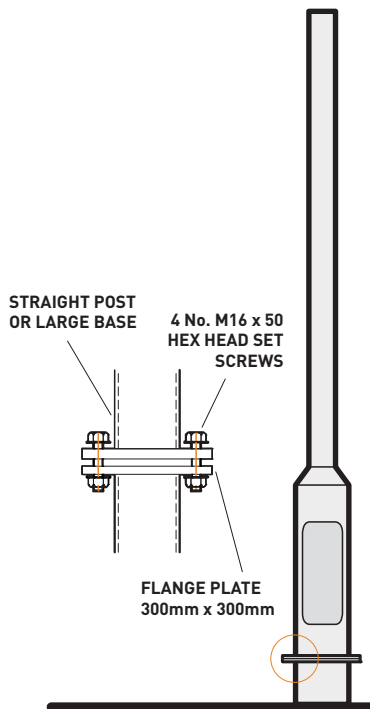

**Demountable Post**

STRAIGHT POST  
OR LARGE BASE

4 No. M16 x 50  
HEX HEAD SET  
SCREWS

FLANGE PLATE  
300mm x 300mm

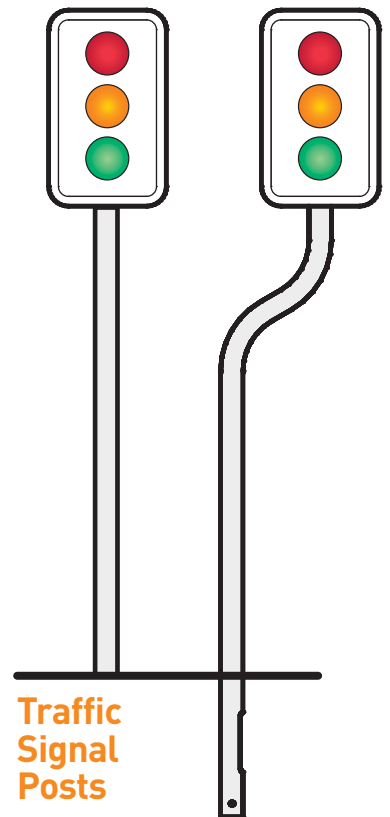

**Traffic  
Signal  
Posts**

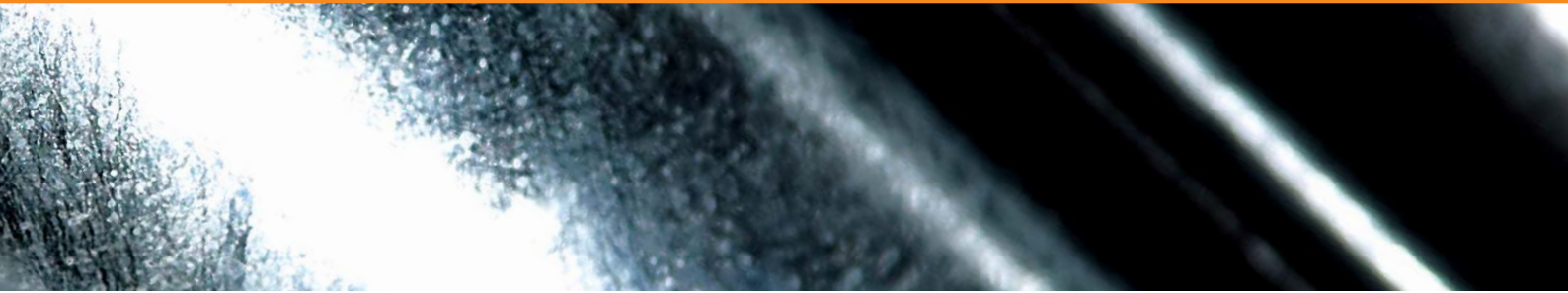

## Cantilever Systems

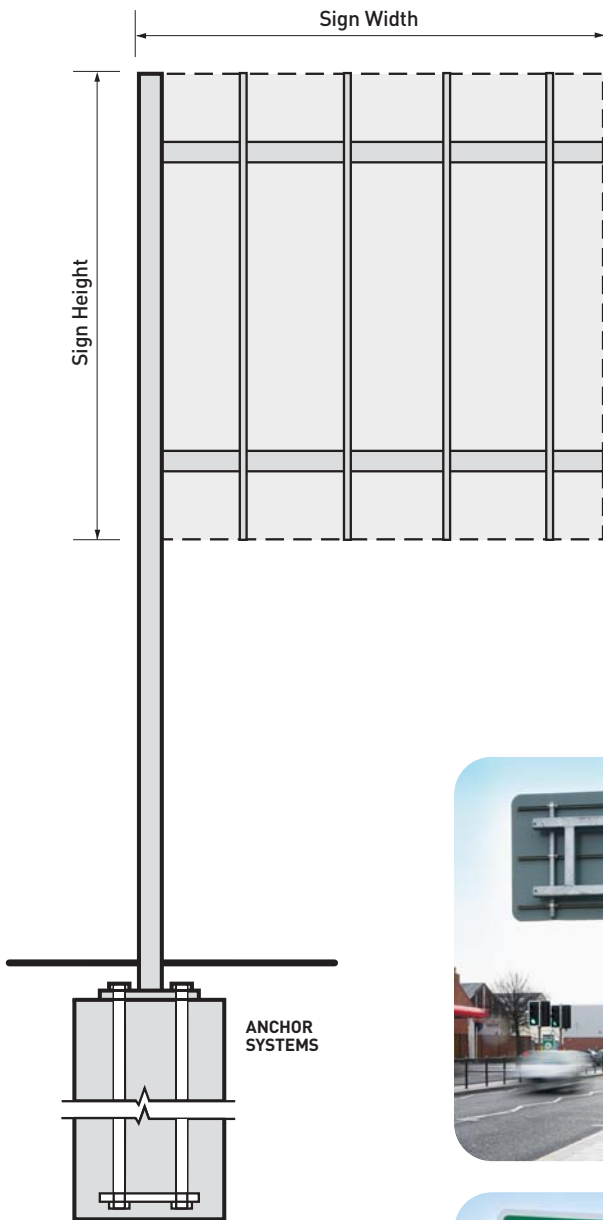

## Large Base Posts

### Shaft Diameter

76 mm  
89 mm  
114 mm  
140 mm

### Base Diameter

140 mm  
168 mm  
194 mm

### Planting Depth

600 mm  
750 mm  
900 mm  
1200 mm

### Door Options

400 x 110 mm  
500 x 110 mm  
600 x 115 mm

## Large Base Post

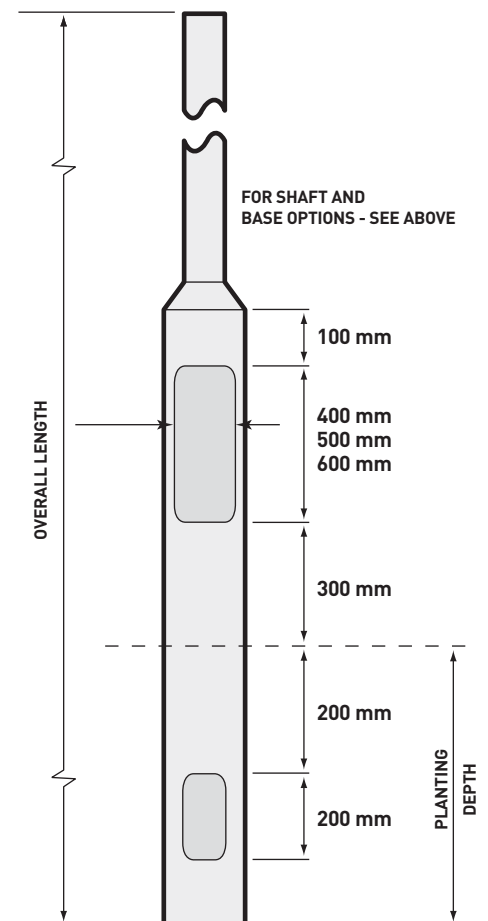

# accessories

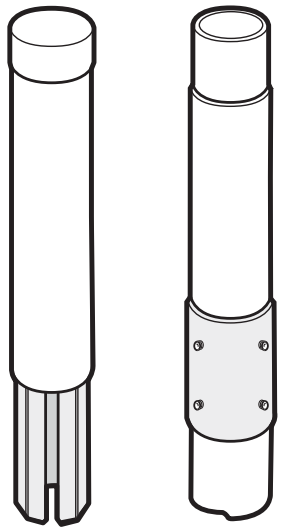

Internal External  
**Post Extensions**

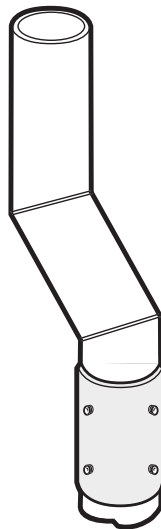

**Cranked Bracket**

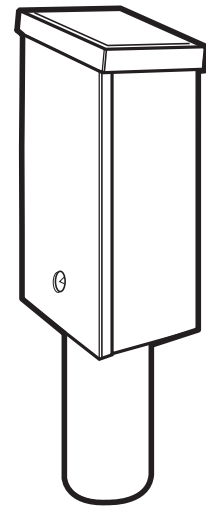

**Root Box**

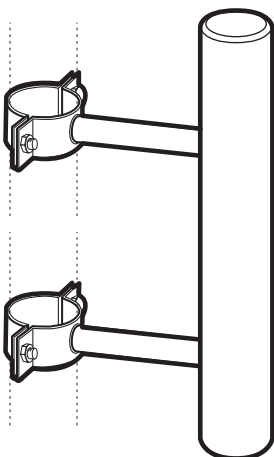

Clip Mount  
**Off Set Bracket**

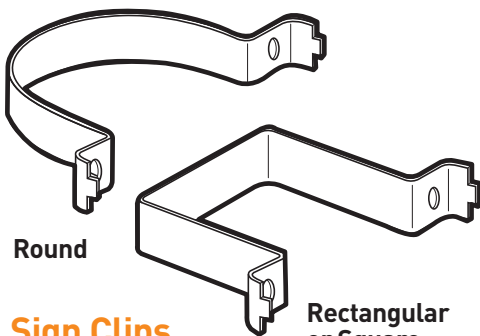

Round

**Sign Clips**

Rectangular or Square

## Post Weight Chart

Size	Wall	kg/m	Size	Wall	kg/m
<b>Circular</b>			<b>Square</b>		
50	3	3.4	50x50	3	4.25
	4	4.5		4	5.45
60.3	3	4.2	60x60	3	5.3
	4	5.6	76x76	3.2	7.3
76.1	3	5.4		4	9
	4	7.1	80x80	3	7.1
88.9	3.2	6.4		4	9.25
	4	8.4	100x100	5	14.4
	5	10.35	120x120	5	17.7
114.3	3.2	8.8	160x160	5	23.8
	3.6	9.85	<b>Rectangular</b>		
	5	13.5	100x50	4	8.9
139.7	4	13.4	120x60	4	10.7
	5	16.6	120x80	4	11.7
	6.3	20.7	150x100	5	18.3
168.3	4	16.3		6.3	22.4
	5	20.1	160x80	5	17.5
	6.3	25.3		6.3	21.4
193.7	5	23.3	200x100	5	22.3
	6.3	29.1		6.3	27.4
	8	36.6	250x150	6.3	37.2
219	5	26.4		8	46.9
	6.3	33.1	300x200	6.3	47.1
	8	41.6		8	59.1
244.5	6.3	37		10	72
	8	46.6	400x200	8	71.8
273	6.3	41.4		10	88.6
	8	52.3	450x250	10	106
	10	99.1		12	132



[www.postandcolumn.co.uk](http://www.postandcolumn.co.uk)

**post+column**

Post and Column Company Ltd  
Road 4, Winsford Industrial Estate  
Winsford, Cheshire CW7 3RS

Tel: 01606 550502 Fax: 01606 550857  
Email: [info@postandcolumn.co.uk](mailto:info@postandcolumn.co.uk)



Signature Ltd  
Hainge Road, Tividale  
West Midlands B69 2NF  
Tel: 0121 557 0234

Part of the Signature Group.



Dee-Organ  
4 Newmains Ave, Inchinnan  
Renfrew PA4 9RR  
Tel: 01418 12 5121



J Wilkinsons  
Unit 10, Parkers Close  
Downton Business Centre, Downton  
Salisbury, Wilts SP5 3RB  
Tel: 0870 777 2792



Approved to National Highways Sector Scheme 6  
Specialist suppliers of Sign Posts and Lighting Columns.