

post+column

steel
lighting
columns



steel lighting columns

The Post & Column Co Ltd has been established for over 20 years and is a leading manufacturer of lighting columns and brackets. All columns are produced in-house at our factory based in Winsford in Cheshire. The factory incorporates a wide range of specialist plant and equipment which has been developed especially for the needs of the lighting column market.

Specification

- Our tubular steel lighting columns are available in mounting heights from 4 to 15 metres.
- All are designed to the latest EN40 standard. The company is also fully registered to National Highway Sector Scheme 6.
- The columns can be used for post top or bracket arm applications. We also supply a range of integral bracket arm arrangements.

Quality Assurance

The Post & Column Company is fully registered to BS EN ISO 9001 and its fabricators and welding procedures are independently certified to BS EN 287 and BS EN ISO 15614-1.



Corrosion Protection

All our galvanizing is carried out to BS EN ISO 1461. In addition a variety of additional treatments are available, these include:

- Paint Finishes – All to full HA specification.
- Thermally applied coatings – These include PVC and PPA coatings. PPA offers an extended life of 25 years plus.

- Root treatments – A variety of root treatments can be applied including high build glass flake systems which can offer extended root life.

All paint and thermal coatings are applied in house by our experienced and fully trained operatives.

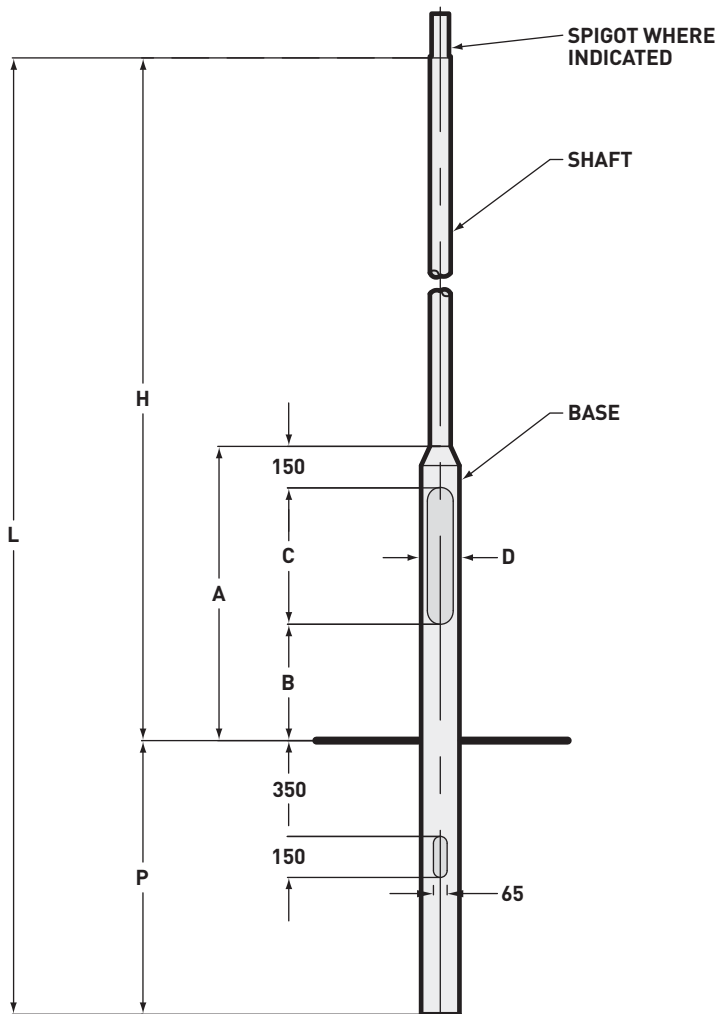

Planted Columns

- Lighting columns fully meet the requirements of EN40.
- Minimum grade of steel BSEN 10219 S275.

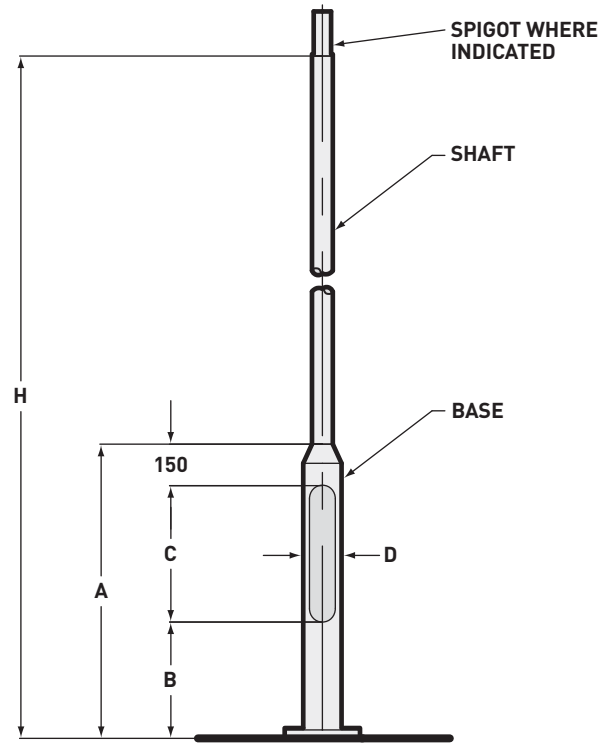

Flanged Columns

- Columns hot tip galvanised to BSEN 1461.
- Column finishes available to all HA specifications.

Flange Detail for Lighting Columns (all dimensions in mm)

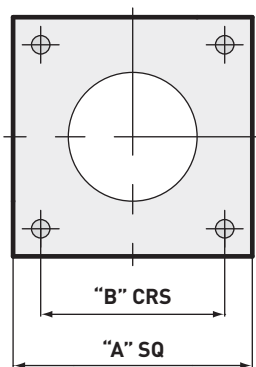

Typical Flange Details		
Column Height H	"A" Square Dimension	"B" Bolt sq. crs
5 & 6 metre	280	200
8, 10 & 12 metre	400	300

BOLT SIZES AND DESIGN LOADS AVAILABLE ON REQUEST



Detailed Specifications (all dimensions in mm)

Column Height H	Column Ref No.	Planting Depth P	Overall Length L	Base Height A	Door to Ground B	Aperture Depth C	Aperture Width D	Base Diameter	Shaft Diameter	Mass kg	Spigot Detail
4 metre	PC0401	800	4800	1075	425	500	100	140	76	42	N/A
5 metre	PC0510	800	5800	1075	425	500	100	140	76	47	N/A
5 metre	PC0502	800	5800	1150	500	500	100	168	89	57	Ø76x200
6 metre	PC0616	1000	7000	1075	425	500	100	140	76	50	N/A
6 metre	PC0603	1000	7000	1150	500	500	100	168	89	60	Ø76x200
8 metre	PC0801	1200	9200	1250	500	600	115	168	89	84	Ø76x200
8 metre	PC0810	1200	9200	1250	500	600	115	168	114	96	Ø101x250
10 metre	PC1014	1500	11500	1250	500	600	115	168	114	142	Ø101x250
10 metre	PC1018	1500	11500	1250	500	600	115	194	140	170	Ø127x300
12 metre	PC1207	1700	13700	1250	500	600	115	194	140	215	Ø127x300

Column Height H	Column Ref No.	Maximum Headload kg	Maximum Allowable Headload m ²				Planted Column Foundations (Ø in mm)		
			Rationalised Wind Location Factors PD6547: 2004				Ground Factor in kN/m ² /metre depth		
			Light	Medium	Heavy	Extra Heavy	230 Poor	390 Average	630 Good
4 metre	PC0401	50	0.7	0.63	0.58	0.44	575	340	210
5 metre	PC0510	50	0.7	0.63	0.58	0.44	575	340	210
5 metre	PC0502	75	1.0	0.95	0.85	0.68	785	465	285
6 metre	PC0616	50	0.41	0.36	0.32	0.23	295	175	None
6 metre	PC0603	75	0.64	0.56	0.52	0.4	400	235	None
8 metre	PC0801	50	0.28	0.24	0.21	0.14	250	None	None
8 metre	PC0810	75	0.7	0.64	0.58	0.46	390	230	None
10 metre	PC1014	50	0.4	0.36	0.32	0.24	220	None	None
10 metre	PC1018	100	1.0	0.9	0.85	0.65	350	205	None
12 metre	PC1207	75	0.58	0.55	0.5	0.35	240	None	None

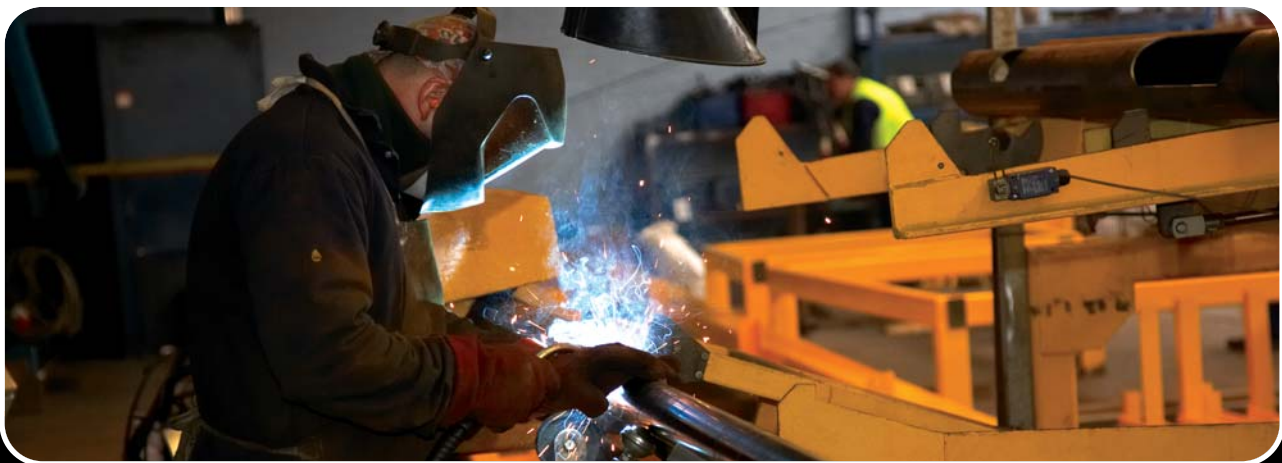

column top and bracket options

Floodlight Brackets

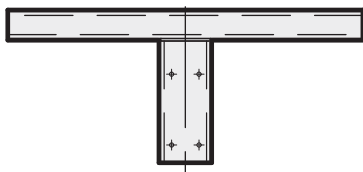

Bracket Fixing (Elevation)



Single/Twin Arm (Plan View)

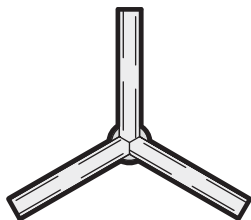

3 Way (Plan View)

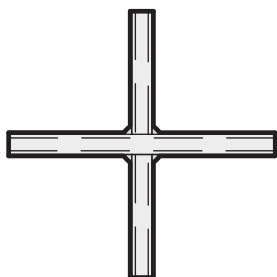

4 Way (Plan View)

Column Brackets

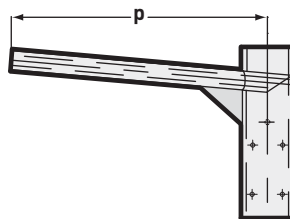

Single Arm (p = projection in mm)

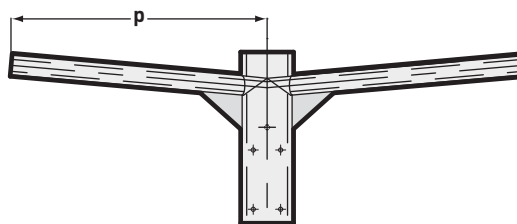

Twin Arm (p = projection in mm)

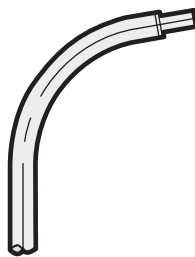

Integral Arm – Hockey Stick

Column Tops



Plain Top



Spigot Top





www.postandcolumn.co.uk

post+column

Post and Column Company Ltd
Road 4, Winsford Industrial Estate
Winsford, Cheshire CW7 3RS

Tel: 01606 550502 Fax: 01606 550857
Email: info@postandcolumn.co.uk



Signature Ltd
Hainge Road, Tividale
West Midlands B69 2NF
Tel: 0121 557 0234

Part of the Signature Group.



Dee-Organ
4 Newmains Ave, Inchinnan
Renfrew PA4 9RR
Tel: 01418 12 5121



J Wilkinsons
Unit 10, Parkers Close
Downton Business Centre, Downton
Salisbury, Wilts SP5 3RB
Tel: 0870 777 2792



Approved to National Highways Sector Scheme 6
Specialist suppliers of Sign Posts and Lighting Columns.